

Reinforced Hydraulic Locking Unit HLU

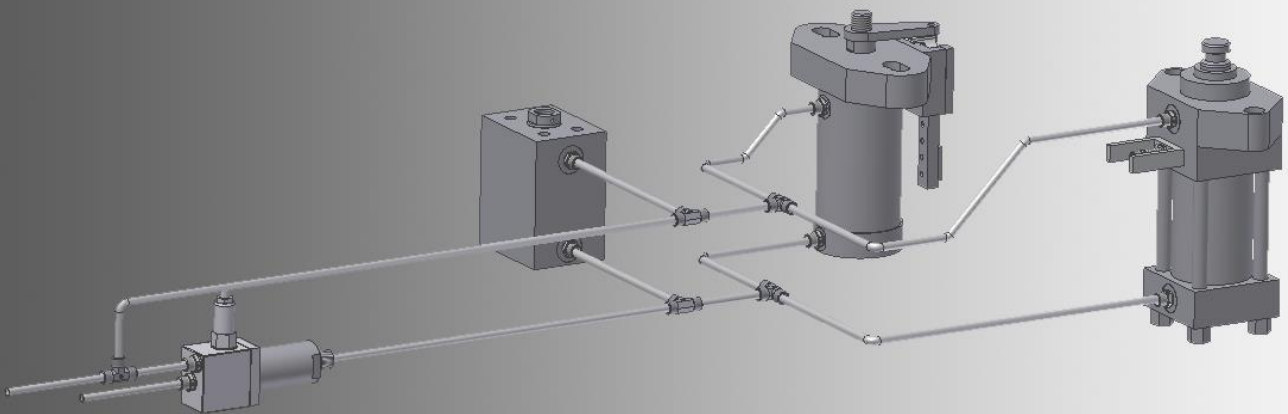

The reinforced hydraulic locking unit HLU makes it possible to hydraulically lock the piston rods of various hydraulic cylinders, regardless of size, type, or stroke, and to simultaneously increase the locking forces significantly as opposed to the forces limited by the system pressure. No additional controls or appliances are necessary for this purpose. The piping effort remains almost the same compared to the standard, because the locking unit is simply being interposed.

Piston rods can be locked hydraulically by confining the oil, which is under pressure, in the cylinder. In this condition, the cylinder is firmly locked as long as there is not more force guided into the cylinder than the confined, pressurized hydraulic fluid can withstand. In case the force limit is exceeded, the piston rod leaves its' position due to the slight compressibility of the hydraulic fluid.

For the reinforced locking unit HLU the locking pressure is many times greater. Hereby, the locking becomes correspondingly firmer and great forces can be carried. The related hydraulic locking cylinders are designed for the high pressure load. The locking unit has no impact on the operating pressure of the rest of the hydraulic system.

This solution makes it possible for example to easily and simultaneously lock various hydraulic shutters at a die-casting mold. This created a significant cost advantage in comparison to the usage of several single locked cylinders.

The additional advantages of the hydraulic locks, the automatic readjustment with every cycle and the easy maintenance, are maintained.



Reinforced Hydraulic Locking Unit HLU

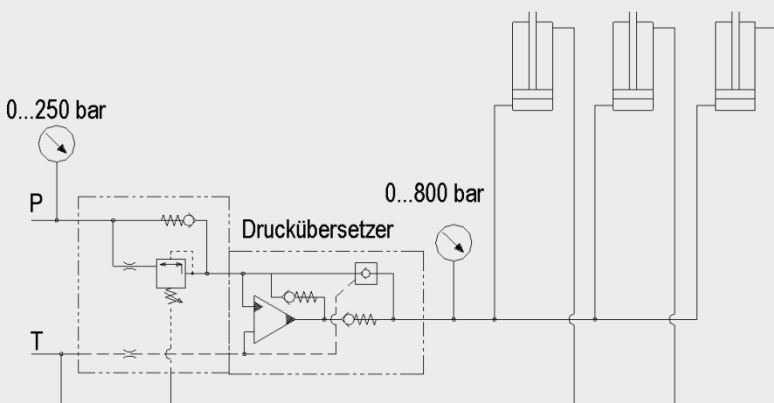

- ▶ Easy integration
- ▶ Low cost with simultaneous usage of several hydraulic cylinders
- ▶ Low piping effort
- ▶ Automatic redelivery

Description:

The hydraulic locking unit by HYDROPNEU increases the system pressure to a multiple of the initial pressure. The locking pressure can be set by a pressure control valve on the inlet side. Once the system pressure of the installation is reached, the locking unit automatically switches over to the pressure increase. Whenever the locking pressure drops, automatic restressing occurs as long as the system pressure is present on the inlet side. Hereby an automatic readjustment of the locking is guaranteed permanently. Locking is possible in the front end position as well as in the rear end position.

Technical Data (Example):

Hydraulic Locking Unit VHE1615-0150-0500-1K	
Operating Pressure Inlet:	20 bar to 200 bar maximum (adjustable)
Operating Pressure Outlet:	20 bar up to max. 640 bar
Volume Flow Inlet:	max. 15 l/min
Volume Flow Inlet (High Pressure):	Max. 2,5 l/min Mean value at pressure build-up of 200 bar on 640 bar
Transmission Ratio:	3,2
Temperature Range:	-40°C up to +120°C
Process Liquids and Gases:	Hydraulic Oil / Water Glycol Mixture
Filtering:	<10 µm

Additional Possibilities:

- ▶ Through a bypass solution on the low-pressure side it is possible to increase the volume flow for the extension of the slides
- ▶ Greater volume flows and pressures also possible on the high pressure side with a complying design

